

This Procedure was developed for Bethgon II's with M101914-003 tub, M102070-005 end closure, M103723-000 or -001 tub clips and may not be applicable directly to all BG II's. Please consult your original drawings or contact FCA Customer Service (814) 533-5056.

CONTENTS

- Text & Illustrated Procedure 2 Pages

1. Block the wheels and apply the handbrake on the car to prevent movement.
2. Apply tub floor per the attached fastener arrangement.
3. Attach the tub clips to the tub floor so that the prescribe gap in step 8 can be achieved.
4. Attach the tub closure to the intermediate crossbearer.
5. Drill or ream a 11/16" diameter hole in the end closure at clip #1 using the hole in the clip angle as a template. Apply a 5/8" x 1 1/2" Una Drive bolt and Stover top lock nut, tighten this connection (nut to be on the outside of tub closure).
6. After completion of step 5, drill or ream a 11/16" diameter hole in the end closure at each of the #2 clip angles (5 places) using the holes in the clip angles as a template. Apply all five 5/8" x 1 1/2" Una Driv bolts and Stover lock nuts and tighten.
7. After completion of step 5, drill or ream an 11/16" diameter hole in the end closure at each of the #3 clip angles (2 places) using the holes in the clip angles as a template. Apply both 5/8" x 1 1/2" Una Driv bolts and Stover lock nuts and tighten.
8. Check the gap between the tub closure and the end of the tub, the gap should be 1/16" minimum and 1/4" maximum all around. If the gap is out of the tolerance range, loosen the tub clip to tub floor Una Drivs and adjust.

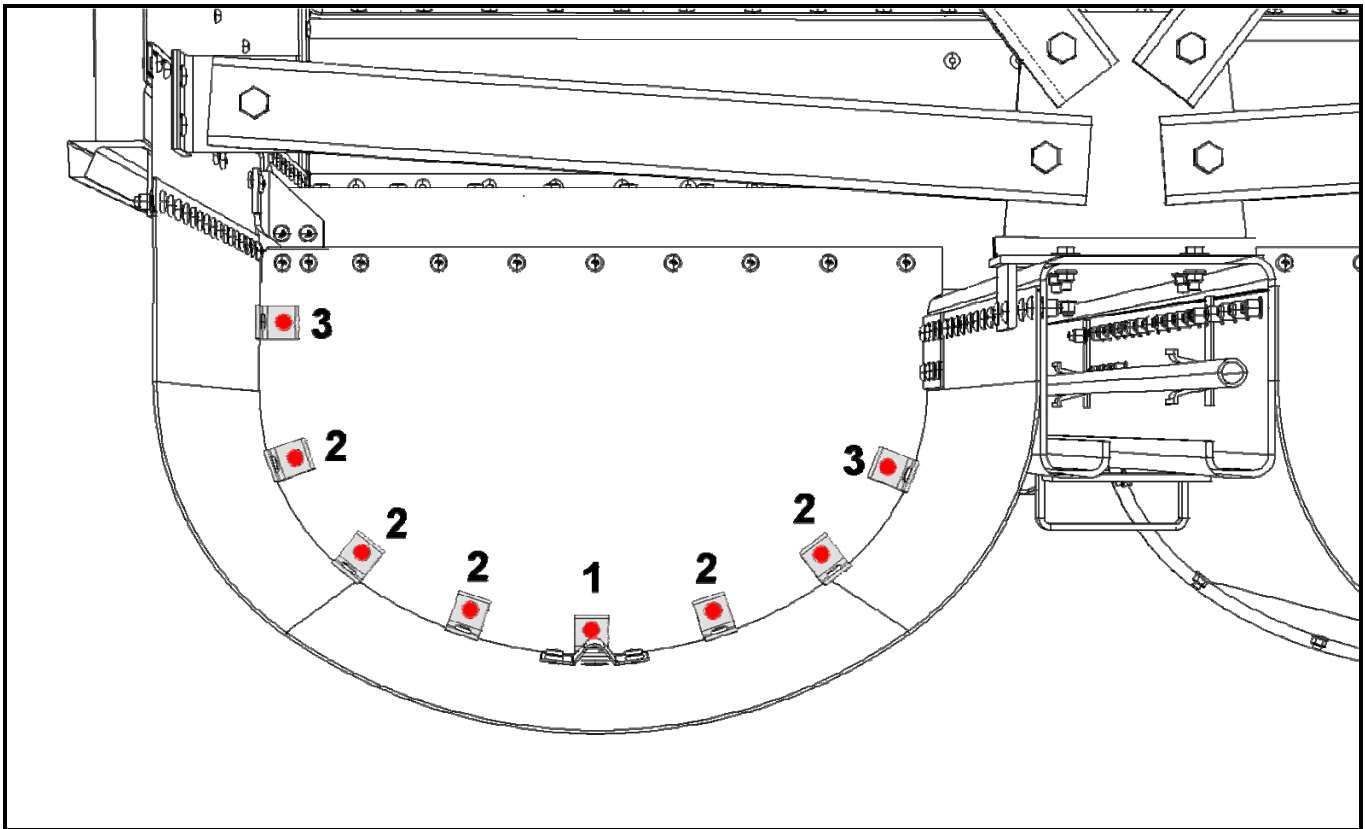

TYPICAL BETHGON II TUB FASTENER ARRANGEMENT

FASTENER BILL OF MATERIAL (per car)

Item No.	Part No.	Description	Quantity
4	10231-008	LOCKBOLT, 20-08	77
5	10231-009	LOCKBOLT, 20-12	48
6	10231-010	LOCKBOLT, 20-16	11
8	10231-013	COLLAR, 3LC-2R20GAL	136
13	10264-001	UNA-DRIV, 5/8" DIA X 1 1/2"	176
14	10264-002	UNA-DRIV, 5/8" DIA X 1 3/4"	32
16	10264-004	NUT, 5/8" UNA-DRIV STOVER	216
17	10264-010	UNA-DRIV, 5/8" DIA X 2 1/4"	8
27	10340-015	WASHER, 5/8", GR8, ZINCPLATED	32

NOTE:
TORQUE RANGE REQUIRED FOR UNA-DRIV BOLTS;
A. WHEN DRIVEN NUT IS IN CONTACT WITH ALUMINUM,
110-160 FT-LBS OF TORQUE IS REQUIRED.
B. WHEN DRIVEN NUT IS IN CONTACT WITH STEEL,
170-210 FT-LBS OF TORQUE IS REQUIRED.

REQUIRED ONLY WHEN
INBOARD INT. CROSSBEARER CONN.
(M101944-010 or -020) IS REPLACED
NOTE : THESE FASTENERS NOT
INCLUDED IN TUB FASTENER BOM

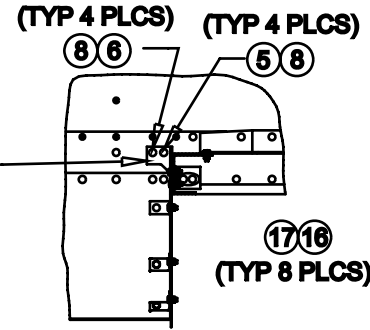

TYPICAL BETHGON II WITH:
M101914-003 TUB FLOOR
M102070-005 TUB CLOSURE
M103723-000 or -001 TUB CLIPS
M10101942-000 TUB CONNECTION FILLER

